

Installation Template

Call Here

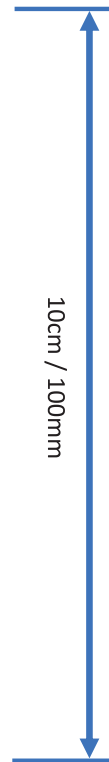
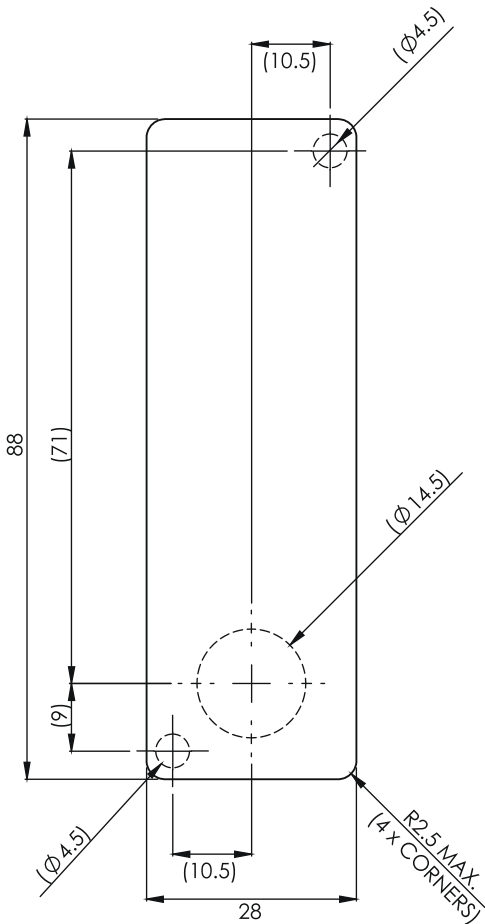
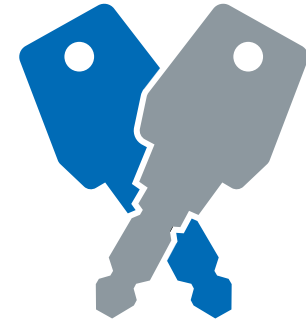

IF USING A PRINTED TEMPLATE,
PLEASE CHECK THIS DIMENSION IS CORRECT

INSTALLATION INSTRUCTIONS

2700 - Gemini Mechanical

IMPORTANT NOTE

For flush fit option, use rectangular aperture (88mm x 28mm)
For surface mount option, use 3 x hole positions

Euro-Locks SA NV
Rue de la Fontaine 8
6600 Bastogne

T: +32 61 212 261
E: sales@euro-locks.be
W: www.euro-locks.com

L&F A Lowe & Fletcher Group Company

V1 July 2017 - 2700 Installation Instructions

euro-locks.com

Gemini
digital and mechanical locks

INSTALLATION INSTRUCTIONS

2700 - Gemini Mechanical

The 2700 lock can be installed in two ways:

- Surface Mount (accessory kit 951700_)
- Flush Mount (accessory kit 951600_)

Surface Mount

- Step 1** Remove all packaging.
- Step 2** Fit the surface mount sleeve to lock as shown in Picture 1.
- Step 3** Position the lock on the outside of the door as shown in Picture 2.
- Step 4** Holding the lock in position, fit the 2 x M4 pan head screws (supplied with the surface mount sleeve) as shown in Picture 3.
- Step 5** Tighten the 2 x M4 screws using a No.2 Posidriv® to 1Nm.
- Step 6** Position the cam onto the rear of the lock as required, fit the cam washer and fixing screw as shown in Picture 6.
- Step 7** Tighten the cam fixing screw using a No.2 Posidriv® to 1.5Nm. Take care not to damage the screw thread when fitting the screw.
- Step 8** Before closing the door, test the lock by selecting the correct User Code and rotating 90°.
- Step 9** Your lock should now be ready to use.

Flush Mount

- Step 1** Remove all packaging.
- Step 2** Position the lock on the outside of the door as shown in Picture 4.
- Step 3** Holding the lock in position, fit the clamp box and 2 x M4 pan head screws (supplied with the clamp box) as shown in Picture 5.
- Step 4** Tighten the 2 x M4 screws using a No.2 Posidriv® to 1Nm.
- Step 5** Position the cam onto the rear of the lock as required, fit the cam washer and fixing screw as shown in Picture 6.
- Step 6** Tighten the cam fixing screw using a No.2 Posidriv® to 1.5Nm. Take care not to damage the screw thread when fitting the screw.
- Step 7** Before closing the door, test the lock by selecting the correct User Code and rotating 90°.
- Step 8** Your lock should now be ready to use.

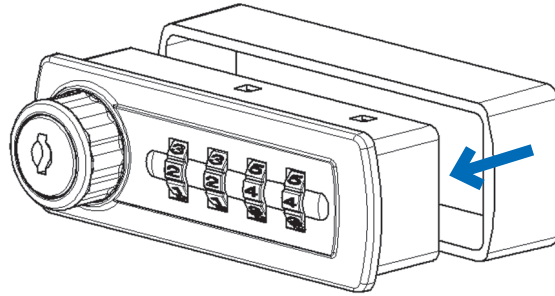

Picture 1.
Fit surface mount sleeve to lock as shown.

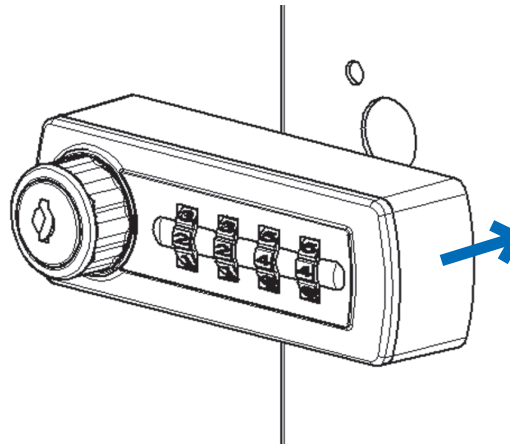

Picture 2.
Position lock on door panel as shown.

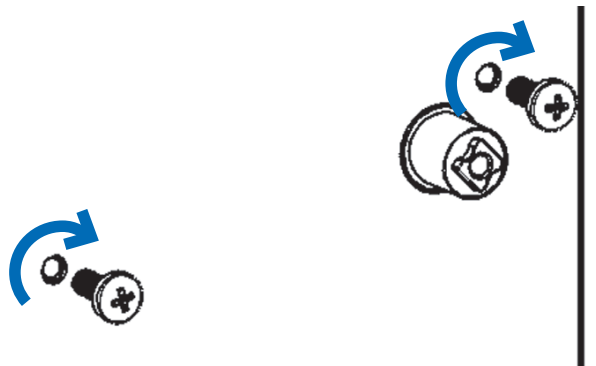

Picture 3.
Fit 2 x M4 pan head screws as shown.

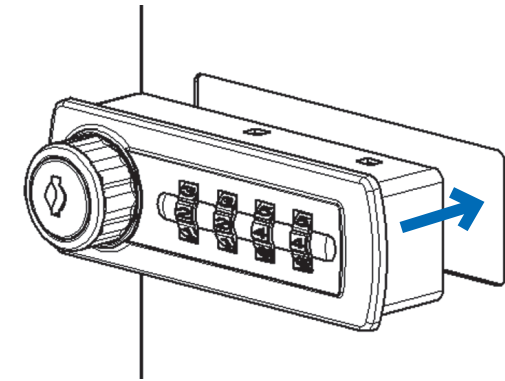

Picture 4.
Position lock through door panel as shown.

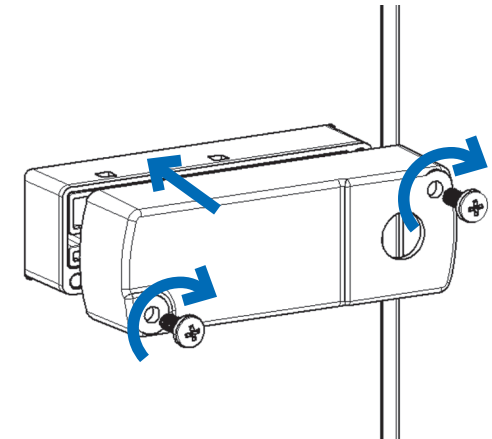

Picture 5.
Fit clamp box and 2 x M4 pan head screws as shown.

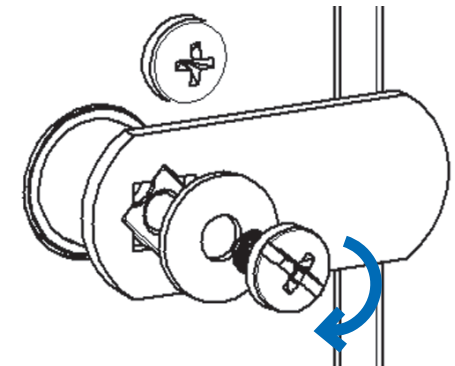

Picture 6.
Fit cam, washer & screw. Tighten with No.2 Posidriv®.