

IF USING A PRINTED TEMPLATE ENSURE THAT THE TEMPLATE IS THE CORRECT SIZE AS PRINTERS VARY

Outline

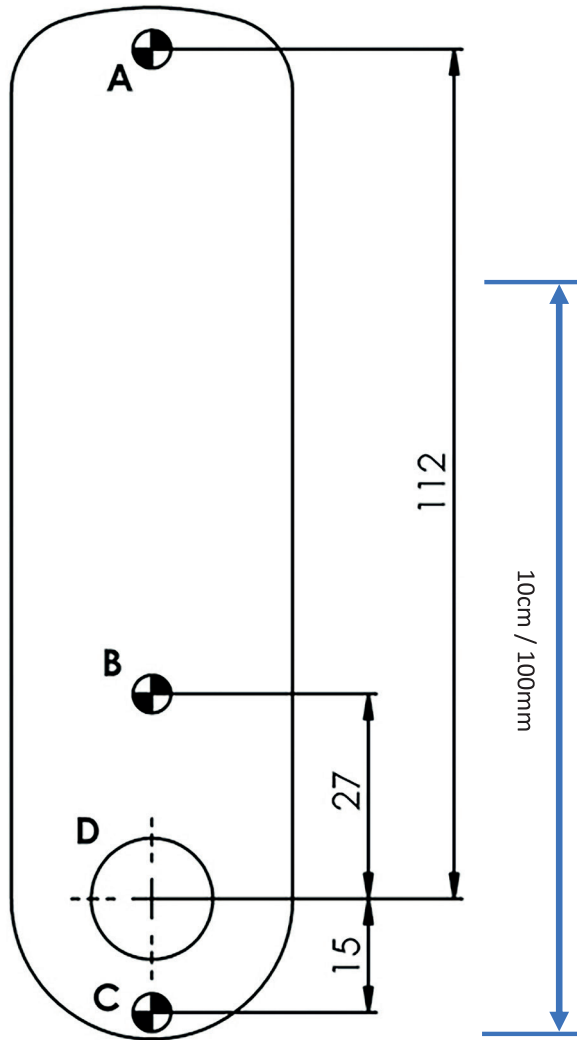

IF USING A PRINTED TEMPLATE,
PLEASE CHECK THIS DIMENSION IS CORRECT

Holes A, B & C diameter 4,5 / 5.0mm
Hole D diameter 16.0 / 16.5mm
Always use fixing hole A and either fixing hole B or C (or both)

IMPORTANT NOTE

Before drilling fixing holes, please ensure that the position of the Digital Combination Lock when fitted will allow clearance for the cam to function.

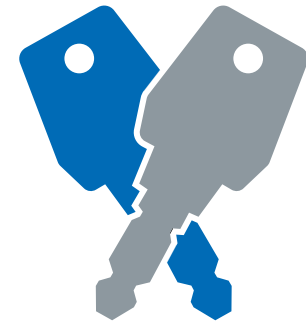

INSTALLATION INSTRUCTIONS

3961- Wet Area Nimbus Surface Mounted Digital Combination Lock

Euro-Locks SA NV
Rue de la Fontaine 8
6600 Bastogne

T: +32 61 212 261
E: sales@euro-locks.com
W: www.euro-locks.com

L&F A Lowe & Fletcher Group Company

3961 Wet Area Nimbus Installation Instructions – Jan 2021

euro-locks.com



INSTALLATION INSTRUCTIONS

3961- Nimbus Wet Area Digital Combination Lock

Fitting Instructions

The Digital Combination Lock can be fitted to cupboards, cabinets and lockers etc. as an original fitment, or as a direct replacement for existing cam locks. It is also retro fitted for a direct replacement for the 378- Digital Combination Lock series.

Special Notes

Before installing the Digital Combination Lock, load the battery and familiarise yourself with the operation and programming.

Unless manufactured to special order, the lock is supplied in the "PRIVATE" operating mode with a four-digit code. In this mode, the user must enter a four-digit User Code to open it. The unit will re-lock itself after 4 seconds. The lock can be opened at any time using the Master Code. Unless manufactured to special order, the default **Master Code** is **11 33 55 77** and the default **User Code** is **22 44**.

These codes are common to all standard locks and it is very important that you set your own personal Master and User Codes. Your lock is not secure until you have changed the default Master Code and User Code. Keep a safe record of your master code as it is not possible to make any programming changes without it.

Please see programming guide to set your own codes.

Installation Guide – Important Notes

The 3961 lock can be fitted with two or three screws. Always use the screw position "A" behind the logo button. Use either "B" or "C" (or both if preferred). Before drilling fixing holes, please ensure that the position of the Digital Combination Lock when fitted will allow clearance for the selected cam to work.

ENSURE BATTERY IS FITTED BEFORE FIXING TO CLOSURE

A) New Installation

Step 1 Place template on door and mark TWO (or three if preferred) Ø4.5mm (3/16") holes (refer to installation diagrams). Use hole position "A" and either "B" or "C". Mark ONE Ø16mm (5/8") hole.

Step 2 Drill all the Ø4.5mm fixing holes and the Ø16mm clearance hole.

Step 3 Fit the escutcheon to the back of the lock.

Step 4 Fit the Digital Combination Lock to the door by passing the spindle through the Ø16mm (5/8") hole.

Step 5 Fix at least 2 fixing screws to suit your door thickness.

Step 6 Select the cam which suits your door and frame and attach it to the square shaft at the end of the spindle using the M4 x 8 patch screw and flat washer provided.

Step 7 Check the operation of the lock using the factory User Code 22 44.

Step 8 If the lock is functioning correctly, CHANGE THE DEFAULT MASTER CODE 11 33 55 77 and DEFAULT USER CODE 22 44 and program the lock using the programming and operating instructions enclosed.

B) Replacing Existing Cam Lock with the 3961 Nimbus Digital Combination Lock

Step 1 Remove existing cam lock.

Step 2 Place installation template on the door over the hole left by the cam lock (position "D") and mark TWO (or three is preferred) Ø4.5mm (3/16") holes (refer to installation diagrams). Use hole position "A" and either "B" or "C".

Step 3 Drill all the Ø4.5mm (3/16") fixing holes.

Step 4 Continue installation from step 3 to 8 as listed above.

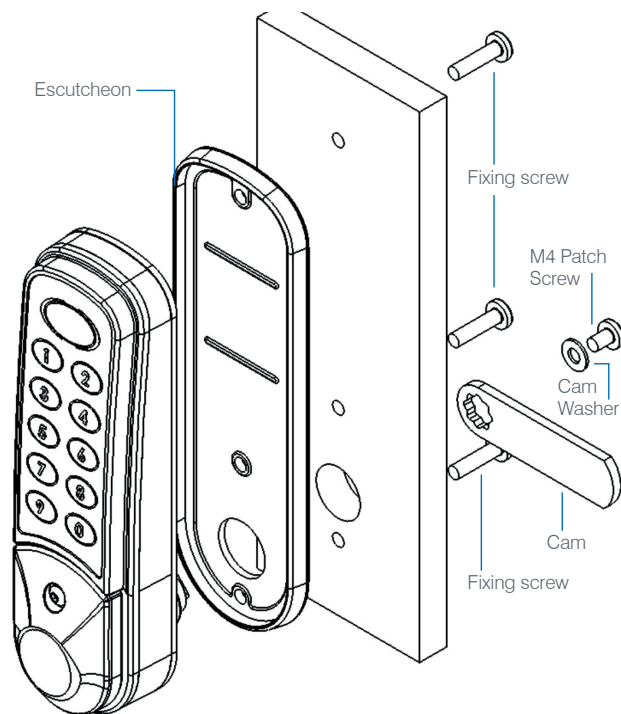

Holes **A**, **B** & **C** diameter 4.5 / 5.0mm
Hole **D** diameter 16.0 / 16.5mm
Always use fixing hole **A** and either fixing hole **B** or **C** (or both)
Recommended screw fixing torque 0.8NM